

# SURFACE VEHICLE RECOMMENDED PRACTICE

**SAE** J1939-81

Issued 1997-07

Revised 2003-05

Superseding J1939-81 JUL1997

## NETWORK MANAGEMENT

### **Forward**

This series of SAE Recommended Practices has been developed by the Truck and Bus Control and Communications Network Subcommittee of the Truck and Bus Electrical and Electronics Committee. The objectives of the subcommittee are to develop information reports, recommended practices, and standards concerned with the requirements, design, and usage of ECUs that transmit electronic signals and control information among vehicle components. The usage of these recommended practices is not limited to truck and bus applications. Other applications may be accommodated with immediate support being provided for construction and agricultural equipment, and stationary power systems.

These documents are intended as a guide toward standard practice and are subject to change to keep pace with experience and technical advances.

Network management in the SAE J1939 network is concerned with the management of source addresses and the association of those addresses with an actual function and with the detection and reporting of network related errors. Due to the nature of management of source addresses, network management also specifies initialization processes, requirements for reaction to brief power outages and minimum requirements for ECUs on the network.

### TABLE OF CONTENTS

<b>1. Scope .....</b>	<b>4</b>
<b>2. References.....</b>	<b>4</b>
2.1 Applicable Publications.....	4
2.1.1 SAE Publications .....	4
<b>3 Definitions .....</b>	<b>4</b>
3.1 Terminology used in network management .....	4
3.2 Controller Application (CA).....	4
3.3 Address Configuration and Capability .....	4
3.3.1 Single Address Capable CA .....	5
3.3.1.1 Non-Configurable Address CA .....	5
3.3.1.2 Service Configurable Address CA .....	5
3.3.1.3 Command Configurable Address CA .....	5
3.3.1.4 Self-Configurable Address CA .....	5

SAE Technical Standards Board Rules provide that: "This report is published by SAE to advance the state of technical and engineering sciences. The use of this report is entirely voluntary, and its applicability and suitability for any particular use, including any patent infringement arising therefrom, is the sole responsibility of the user."

SAE reviews each technical report at least every five years at which time it may be reaffirmed, revised, or canceled. SAE invites your written comments and suggestions.

**QUESTIONS REGARDING THIS DOCUMENT: (412) 776-0243**  
**TO PLACE A DOCUMENT ORDER; (412) 776-0790**  
**SAE WEB ADDRESS <http://www.sae.org>**

3.3.2	Arbitrary Address Capable CA .....	6
3.4	Types of CAs .....	6
3.4.1	Standard CAs.....	6
3.4.2	Diagnostic/Development Tool CAs.....	6
3.4.3	Network Interconnection CAs.....	6
<b>4.</b>	<b>Technical Requirements .....</b>	<b>7</b>
4.1	NAME and Address Requirements .....	7
4.1.1	NAME .....	8
4.1.1.1	NAME Fields .....	9
4.1.1.2	Arbitrary Address Capable Field .....	10
4.1.1.3	Industry Group Field.....	10
4.1.1.4	Vehicle System Instance Field.....	10
4.1.1.5	Vehicle System Field .....	10
4.1.1.6	Reserved Field.....	10
4.1.1.7	Function Field.....	10
4.1.1.8	Function Instance Field .....	10
4.1.1.9	ECU Instance Field .....	11
4.1.1.10	Manufacturer Code Field .....	11
4.1.1.11	Identity Number Field.....	11
4.1.1.12	Dependencies in the NAME Fields .....	11
4.1.2	Addresses .....	12
4.1.2.1	The 254 Address.....	12
4.1.2.2	The 255 Address.....	12
4.2	Network Management Procedure .....	13
4.2.1	Request Message (PGN 59904) for Address Claimed (PGN 60928) .....	13
4.2.2	Address Claimed / Cannot Claim (PGN 60928) .....	14
4.2.2.1	Address Claimed Message .....	15
4.2.2.2	NAME of Controller Application .....	15
4.2.2.3	Cannot Claim Address.....	15
4.2.3	Commanded Address (PGN 65240).....	16
4.2.3.1	Commanded Address Message.....	16
4.2.3.2	NAME of Commanded Address Target.....	17
4.2.3.3	Address Assignment (new source address).....	17
4.2.4	Working Sets .....	17
4.2.4.1	Application Notes .....	18
4.2.4.1.1	Message sequence .....	18
4.2.4.1.2	Working Set Member Message Spacing .....	18
4.2.4.1.3	Compatibility with Conventional Network Processes .....	18
4.2.4.1.4	Constraints on Working Set Membership .....	19
4.2.4.1.5	Configuration Changes .....	19
4.2.4.1.6	Source Address Changes.....	19
4.2.4.1.7	Missing Working Set Members .....	19
4.2.4.2	Working Set Master Message – WSMSTR (PGN 65037) .....	20
4.2.4.3	Number of Members .....	20
4.2.4.4	Working Set Member Message – WSMEM (PGN 65036) .....	20
4.2.4.5	NAME of Working Set Member.....	21
4.3	Network Error Management .....	21
4.3.1	Cannot Claim Address .....	21
4.4	Address Claim and CA Initialization procedure.....	21

4.4.1 Address Claim Prioritization .....	22
4.4.2 Address Claim Requirements .....	22
4.4.2.1 Requirements for Requests for Address Claimed .....	22
4.4.3 Address Claim Initialization Rules .....	22
4.4.3.1 Response to a Request for Address Claimed sent to the global address .....	22
4.4.3.2 Response to a Request for Address Claimed sent to a specific address .....	22
4.4.3.3 Response to Address Claims of Own Address .....	23
4.4.3.4 Contention for an Address .....	23
4.4.4 Message Sequences for Initialization .....	23
4.4.4.1 Message sequences for initialization for all CAs on the network .....	23
4.4.4.2 Potential Identical Identifiers in Network Management Messages .....	23
4.4.4.3 Address Claim Bus Collision Management .....	24
4.4.4.4 A CA which is Unable to Successfully Obtain an Address. ....	24
4.4.5 Requests for Address Claimed for Self-Configurable Addressing CAs .....	24
4.4.5.1 Technical Note Regarding Multiple Self-Configurable Addressing CAs .....	25
4.4.5.2 CAs Not Permanently Connected to the Network. ....	25
4.4.6 Construction of Address to NAME Association Tables .....	25
4.5 Minimum Network Management Functionality .....	25
4.5.1 Reaction to Power Supply and Other Related ECU Disturbances .....	25
4.5.2 Minimum Network Management Capability .....	26
4.5.2.1 Request for Address Claimed Message .....	26
4.5.2.2 Address Claimed Message before Using a Source Address .....	26
4.5.2.3 Disruption of the Network During Connection or Disconnection of an ECU .....	26
4.5.2.4 Continuity of Addresses Across Power-down and Power-up Cycles .....	26
<b>Appendix A: Initialization Sequence Timing Diagrams .....</b>	<b>27</b>
FIGURE A1 - Initialization of A CA with Address Claim and No Contention .....	27
FIGURE A2 - Initialization of an ECU Where Two Single Address CAs Attempt To Claim the Same Address But Not Simultaneously .....	27
FIGURE A3 - Initialization of a CA Where NAME A Is Less Than NAME B and CA B is Arbitrary Address Capable .....	28
FIGURE A4 - Initialization of a CA with Two CAs Attempting to Claim the Same Address Simultaneously .....	28
<sup>1</sup> Single Address CAs with addresses in the 0-127 and 248-253 ranges may omit the 250 ms delay. ...	29
FIGURE A5 - Initialization of an Arbitrary Address Capable CA with No Contention .....	29
FIGURE A6 - Initialization of an Arbitrary Address Capable CA with a Request for Address Claimed Sent to the Global Address .....	29
FIGURE A7 - Initialization of a Single Address CA with a Request for Address Claimed Where Address Is In Use .....	30
FIGURE A8 - Response to a Request for Address Claimed by a CA which has Been Earlier Unsuccessful In Claiming an Address .....	30
FIGURE A9 - Commanding an Address of a CA which does not have an Address and Supports the Commanded Address Message .....	31
FIGURE A10 - Commanding an Address of a CA which does not have an Address and the Commanded CA Does Not Support A Commanded Address Message .....	31
<b>Appendix B Summary of Requirements and Capabilities of CAs .....</b>	<b>32</b>
<b>Appendix C NAME Examples .....</b>	<b>33</b>
<b>C.1 NAME Examples .....</b>	<b>33</b>
C.1.1 A Single ECU with a CA Serving an Engine on an On-Highway Heavy-Duty Truck .....	33
C.1.2 Brakes on the second trailer of heavy-duty truck .....	33

C.1.3 Agricultural planters with separate Section Controls.....34

**Appendix D: State Transition Diagrams for Address Claiming Processes.....35**

FIGURE D1 - State Transition Diagram for Initialization of Arbitrary Address Capable CAs ..... 36

FIGURE D2 - State Transition Diagram for Initialization of Single Address CAs ..... 37

FIGURE D3 - State Transition Diagram for Response of a CA to the Commanded Address Message 38

**1. Scope**

These SAE Recommended Practices are intended for light and heavy duty vehicles used on or off road as well as appropriate stationary applications which use vehicle derived components (e. g. generator sets). Vehicles of interest include, but are not limited to on and off highway trucks and their trailers; construction equipment; and agricultural equipment and implements.

The purpose of these documents is to provide an open interconnect system for electronic systems. It is the intention of these documents to allow Electronic Control Units to communicate with each other by providing a standard architecture.

Network management in the SAE J1939 network is concerned with the management of source addresses and the association of those addresses with an actual function and with the detection and reporting of network related errors. Due to the nature of management of source addresses, network management also specifies initialization processes, requirements for reaction to brief power outages and minimum requirements for ECUs on the network.

**2. References**

General information regarding this series of recommended practices is found in SAE J1939.

**2.1 Applicable Publications**

Available from SAE, 400 Commonwealth Drive, Warrendale, PA 15096-0001.

**2.1.1 SAE Publications**

- SAE J1939 - Recommended Practice for Serial Control and Communications Vehicle Network
- SAE J1939-21 - Data Link Layer
- SAE J1939-31 - Recommended Practice for Serial Control and Communications Vehicle Network - Part 31- Network Layer

**3 Definitions**

See SAE J1939 top level document for definition of terms not defined in this document.

**3.1 Terminology used in network management**

Terms are defined in SAE J1939 for use in the context of this document.

**3.2 Controller Application (CA)**

For the purposes of this document, a controller is made up of the software and the hardware within an Electronic Control Unit (ECU) that performs a particular control function. The software within a particular controller is the "Controller Application" (CA). An ECU may serve as one or more controllers and hence may contain one or more CAs. Each CA will have one address and an associated NAME in order to communicate on the J1939 network.

**3.3 Address Configuration and Capability**

Address configuration is the method by which a particular CA determines the source address it will use for Address Claim. For the purposes of the Address Claim process, there are two capabilities: Single Address Capable and Arbitrary Address Capable. These are distinguished by the value in the Arbitrary Address Capable field at the high-order position in the CA's NAME. The terms and definitions follow:

### **3.3.1 Single Address Capable CA**

Within the Single Address Capable group, there are several different methods by which the CA can have its address changed. All but one involve an external agent. These CAs have no means to alter the address they claim and use without intervention through some external process. These CAs include non-configurable address, service configurable address, command configurable address and self-configurable address CAs. The value in the Arbitrary Address Capable field is zero in the NAME of these CAs. Four classifications of CAs are defined below to allow different methods of changing the targeted source address. These classifications are not necessarily mutually exclusive. For example, an ECU that is a Self-Configurable Address CA could simultaneously be a Service Configurable Address CA and a Command Configurable Address CA. A designer may allow this just in case the CA is unable to claim any of the addresses within its limited set.

#### 3.3.1.1 Non-Configurable Address CA

A Non-Configurable Address CA is one which has a source address provided by its manufacturer. This address is not alterable by any means in the field, including service procedures. (Note that a "Service Procedure" that replaces the software that is executing in the ECU and thereby defining the CA may still change the address used by the CA.)

#### 3.3.1.2 Service Configurable Address CA

A Service Configurable Address CA is one whose source address may be changed in the field by a service technician. The address may be altered by any one of a number of proprietary techniques or by using the Commanded Address message, while in a "service" mode of operation. It is very likely that a service tool would be involved.

#### 3.3.1.3 Command Configurable Address CA

A Command Configurable Address CA is one whose source address can be altered using the Commanded Address message. The change can take place as the ECUs on the vehicle power up, without the intervention of a service tool or the requirement of a special service mode of operation. It does require the presence on the vehicle of a CA that can send the appropriate command to cause the address change, and code in the Command Configurable Address CA to recognize and authenticate that command.

#### 3.3.1.4 Self-Configurable Address CA

This is a special case where the CA is capable of determining which one of a limited set of Source Addresses it will use based on information it obtains from the vehicle's configuration. A prime example of this is a Trailer Bridge that determines that it is Trailer No. 2 in a vehicle. While it can change the Source Address (SA) it will use based on this internal determination, it can use only that address while it is in that particular position on the vehicle. If that trailer were moved to Trailer No. 1 position, the CA would use the address specified for Trailer No. 1. Note that there is just one address that is appropriate for use at each position: the CA first learns its position, then creates the new NAME using that position information, then chooses the appropriate address. A device that uses information from a connector plug to determine whether it is on the left or right side of the vehicle would also be in this class. Note that these CAs are capable of changing their addresses solely on the basis of a change in NAME.

### 3.3.2 Arbitrary Address Capable CA

An Arbitrary Address Capable CA is one that can select its source address from any appropriate SA (including those in the range 128 to 247 inclusive) based on internal algorithms, and then claim that address. This CA, in cases of address conflict, is also able to re-calculate its address and re-claim (unless all 120 of the addresses between 128 and 247 are used). The value in the Arbitrary Address Capable field in the NAME (See Section 4.1.1.2) indicates whether or not a CA has this capability. This capability is needed particularly for CAs that are expected to have multiple instances of the same device on a single vehicle. In these cases, the Arbitrary Address Capable CA will be the one to lose arbitration for a Preferred Address since the setting of the Arbitrary Address Capable bit in its NAME lowers its priority for address claim. This is correct behavior since its ability to operate correctly on the network will not be affected by the loss of arbitration. Note that if its function is one that would normally use a Preferred Address in the lower 128, it will claim that address first. Only upon losing arbitration during Address Claim will it claim an unused address from the range above 128.

## 3.4 Types of CAs

For the purposes of network management, there are three types of CAs: Standard, Diagnostic/Development Tools, and Network Interconnection CAs.

### 3.4.1 Standard CAs

Standard CAs are those CAs whose primary function is not that of network interconnection or of programming, diagnosing, or otherwise functioning as tools or network interconnection CAs.

Standard CAs include those used for engines, transmissions, brakes, virtual terminals, instrument clusters, and vehicle navigation. Data loggers and recorders are also examples of standard CAs but if these CAs assume diagnostic tool functions then they should meet requirements of diagnostic tool CAs. Standard CAs do not have the ability to modify the source addresses of any other CAs except as a result of the address claiming process.

Standard CAs may or may not possess any of the addressing capabilities listed in section 3.3. It is not the intent of this document to require a particular address configuration capability for any Standard CA.

### 3.4.2 Diagnostic/Development Tool CAs

Diagnostic and Development Tool CAs are those which are connected to a particular SAE J1939 subnetwork for the purpose of analyzing, debugging, developing or monitoring any CA on the subnetwork or the operation of the subnetwork itself. Although these tools are not expected to be permanently attached to a subnetwork, such a tool may well be a permanent part of a particular vehicle or craft. In either case, the capabilities of these tools are more extensive than those of Standard CAs. They are primarily designed to interact with other CAs on the network and have no other external functionality (a diagnostic tool, for example, is not expected to provide torque, plant beans, or brake a vehicle).

These tools may be intended as proprietary tools to operate on or in a given manufacturer's ECUs. They may be intended as a general-purpose tool to operate on ECUs provided by several manufacturers. Or they may be intended to work primarily on the network itself, providing network integration services for system integrators and OEM vehicle manufacturers.

### 3.4.3 Network Interconnection CAs

Network Interconnection CAs are those that exist primarily for the purpose of interconnecting networks or subnetworks. They primarily consist of repeaters, bridges, routers and gateways. In one manner or another, all network interconnection CAs forward messages from one subnetwork to another.

Subnetworks interconnected by Network Interconnection CAs may have the same protocol, as in two SAE J1939 subnetworks in the same vehicle; they may have different protocols, such as from SAE J1708/J1587 to SAE J1939, or may be interconnected off-vehicle subnetworks, such as satellite link, token ring or cellular modem.

Network Interconnection CAs serving as gateways translate from SAE J1939 subnetworks to various other networks. This document will deal only with the SAE J1939 portions of those CAs.

#### **4. Technical Requirements**

The Network Management layer in an SAE J1939 network provides the definitions and procedures necessary to uniquely identify CAs on the network, manage the assignment of addresses, and manage network errors.

- ◆ Each CA must be capable of providing its unique 64-bit NAME. The rules for creating this NAME, associating it with an address and the ability or non-ability to change that address are presented in section 4.1 “NAME and Address Requirements”.
- ◆ CAs must successfully claim an address according to the procedures explained in section 4.2 “Network Management Procedure” prior to sending any other messages on the network. Multiple ECUs and/or CAs can work together to perform functions but must follow the rules in section 4.2.4.
- ◆ The inability to successfully claim an address according to the procedure must be handled and reported to the network in a standard way expressed in section 4.3.
- ◆ Network initialization sequences associated with the address claiming process are described in section 4.4.
- ◆ A minimum set of network management requirements, including required responses to power interruptions are listed in section 4.5.

#### **4.1 NAME and Address Requirements**

Addresses are used within SAE J1939 networks to provide uniqueness to message identifiers and to allow the source of a message to be determined. (Addresses are sometimes referred to as “Source Addresses” indicating the latter use). Address claim messages, which contain both a source address and a NAME, are used to associate a NAME with a particular address on the network.

Every CA that transmits messages on a SAE J1939 network must have a NAME and successfully acquire an Address before the CA may transmit normal network traffic. The NAME serves two purposes, first, to provide a functional description of the CA (e.g. Engine Number 1, Engine Number 2, Transmission Number 1, Anti-Lock Brake System 1) and second, to provide a numerical value that may be used in arbitration for addresses. Addresses are used within SAE J1939 networks to provide uniqueness to message identifiers and to allow the source of a message to be determined. (Addresses are sometimes referred to as “Source Addresses” indicating the latter use). Address claim messages, which contain both a source address and a NAME, are used to associate a NAME with a particular address on the network. The association of an address with a unique NAME (4.1.1) also provides means to associate an address with a CA. Manufacturers of ECUs and integrators of networks must assure that the NAMES of all CAs intended to transmit on a particular network are unique.

**4.1.1 NAME**

A NAME is a 64-bit identifier for a CA and is composed of 10 fields. The values for 6 of these fields are derived from assignment lists managed by the J1939 committee. The remaining 4 values are either derived from characteristics of the network and vehicle architecture or under direct control of the manufacturer.

Source addresses in the SAE J1939 network serve to identify a particular CA that is communicating on a given network. The NAME associated with a CA, as opposed to the address, provides the primary identification of the CA and the Function that the CA has on the network. Address management procedures in the network management protocol allow the association of individual source addresses with the NAME of the CA, and the announcement of that association onto the network. Appendix C provides examples of the construction of NAMES for SAE J1939 ECUs.

Each CA on a network should have one NAME so the CA may be uniquely identified by its primary function. A CA's NAME is also used in arbitration when multiple CAs attempt to claim the same address, reinforcing the need for unique identification. In turn, each CA on the network will have a single address, which is unique, so that it can properly arbitrate CAN Data Frames with other ECUs.

Although the entire NAME need not be field programmable, the instance fields should be alterable to allow for the correct configuration when, for example, a spare is installed in the field, or multiple instances may exist on a vehicle. Field programmability of the entire NAME field as well as the preferred address is recommended. NAMES may be programmed through use of the memory access protocol with Directed Spatial Addressing. The pointer Extension should be set to  $0000000_2$  indicating SPN Space with SPN of the NAME of Controller Application (SPN 2848) used as the index of the desired object as described in J1939-73.

NAMES are composed of fields as shown in Table 1 and 2, and are defined in the following paragraphs.

**Table 1: NAME Fields**

Arbitrary Address Capable	Industry Group	Vehicle System Instance	Vehicle System	Reserved	Function	Function Instance	ECU Instance	Manufacturer Code	Identity Number		
1 bit 4.1.1.2	3 bit 4.1.1.3	4 bit 4.1.1.4	7 bit 4.1.1.5	1 bit 4.1.1.6	8 bit 4.1.1.7	5 bit 4.1.1.8	3 bit 4.1.1.9	11 bit 4.1.1.10	21 bit 4.1.1.11		
Byte 8			Byte 7		Byte 6	Byte 5		Byte 4	Byte 3	Byte 2	Byte 1

Listings of numerical values for Industry Groups, Vehicle Systems, Functions, and Manufacturer Codes are found in the Appendix B of SAE J1939 top-level document.

The byte ordering of the NAME fields in a CAN message is shown in table 2, and is arranged to allow the NAME to be treated as a number in a manner consistent with SAE J1939-71. The entire 8 byte NAME is used as a single numeric value in arbitration processes when multiple CAs attempt to claim the same address (see 4.4.3.3).



**Table 2: Field positions within NAME**

Byte	Bits	Position of Most Significant bit	Description	Note:
1	8-1	8	Least significant byte of Identity Number	Bit 8 is the bit sent closest to the DLC bits of the message.
2	8-1	8	Second byte of Identity Number	
3	8-6	8	Least significant 3 bits of Manufacturer Code	Bit 1 is the last of the data bits sent and is closest to the CRC in the message.
	5-1	5	Most significant 5 bits of Identity Number	
4	8-1	8	Most significant 8 bits of Manufacturer Code	
5	8-4	8	Function Instance	
	3-1	3	ECU Instance	
6	8-1	8	Function	
7	8-2	8	Vehicle System	
	1	-	Reserved	
8	8	-	Arbitrary Address Capable	
	7-5	7	Industry Group	
	4-1	4	Vehicle System Instance	

**4.1.1.1 NAME Fields**

These fields are prioritized from left to right as shown in Table 1. The meaning of the contents of the Vehicle System field is dependent on the Industry Group field contents. Further, the contents of the Function field is dependent on the Vehicle System field contents when the value for Function is greater than 127 and less than 254. Figure 1 illustrates the relationship between the field definitions. The Vehicle System and Function fields may be set to indicate Not Available (binary ones) if values for these fields are not known or not defined in J1939. All other fields in the NAME must be set to their proper value. Table 3 summarizes this requirement.

**Table 3: Summarized requirements for setting values in NAME fields**

Field	Ability to be set to "Not Available"
Arbitrary Address Capable	No
Industry Group	No
Vehicle System Instance	No
Vehicle System	Yes
Reserved	No
Function	Yes
Function Instance	No
ECU Instance	No
Manufacturer Code	No
Identity Number	No

#### 4.1.1.2 Arbitrary Address Capable Field

This 1-bit field indicates whether a CA can use an arbitrary source address to resolve an address claim conflict. If this bit is set to "1", the CA will resolve an address conflict with a CA whose NAME has a higher priority (lower numeric value) by selecting an arbitrary source address from the range 128 to 247 inclusive and claiming that source address.

A self-configurable CA that computes its address but can claim only from a more restricted set of addresses is not considered arbitrary address capable (e.g. On-Highway Trailers.) See section 4.2 of this document for details of the address claim process.

#### 4.1.1.3 Industry Group Field

Industry Group is a 3-bit field defined and assigned by the committee. Industry Group definitions may be found in Appendix B.7 of the SAE J1939 base document. The Industry Group field identifies NAMEs associated with a particular industry that uses SAE J1939, for example: On-Highway Equipment, or Agricultural Equipment.

#### 4.1.1.4 Vehicle System Instance Field

Vehicle System Instance is a 4-bit field that is used to identify a particular occurrence of a particular Vehicle System within a connected network.

Note that in the case of single or first Vehicle System of a particular type, the instance field should be set to zero indicating the first instance.

#### 4.1.1.5 Vehicle System Field

Vehicle System is a 7-bit field defined and assigned by the committee, which when combined with the Industry Group can be correlated to a common name. See J1939 (top-level document) Appendix B, Table B12. Vehicle System provides a common name for a group of functions within a connected network. Examples of Vehicle Systems for currently defined Industry Groups are "tractor" in the "Common" Industry Group, "Trailer" in the On-Highway Industry Group, and planter in the "Agricultural Equipment" Industry Group.

#### 4.1.1.6 Reserved Field

Reserved for future definition by SAE. The reserved bit should be set to zero.

#### 4.1.1.7 Function Field

Function is an 8-bit field defined and assigned by the committee. When Function has a value of 0 to 127 (See J1939 top level document, Appendix B, Table B11), its definition is not dependent on any other field. When Function has a value greater than 127(See Appendix B, Table B12), its definition depends on Vehicle System. Function, when combined with the Industry Group and the Vehicle System fields identifies a common name for a specific controller. The common name formed from the combination does not imply any specific capabilities.

#### 4.1.1.8 Function Instance Field

The Function Instance is a 5-bit field that identifies the particular occurrence of a Function on the same Vehicle System on a given network.

Note that in the case of single or first Function of a particular type, the instance field should be set to zero indicating the first instance.

Individual manufacturers and integrators are advised that some agreement in the interpretation and use of Function Instances may be necessary. As an example, consider an implementation consisting of two engines and two transmissions. It may be important that engine instance 0 is physically connected to transmission instance 0 and that engine instance 1 is physically connected to transmission instance 1.

4.1.1.9 ECU Instance Field

The ECU Instance is a 3-bit field that indicates which one of a group of electronic control modules associated with a given Function is being referenced. For example, in the case where a single engine is managed by two separate control units, each of which is attached to the same SAE J1939 network, the ECU Instance Field will be set to 0 for the first ECU and 1 for the second ECU.

Note that in the case of a single or first ECU for a particular CA, the instance field should be set to zero indicating the first instance.

4.1.1.10 Manufacturer Code Field

The Manufacturer Code is an 11-bit field that indicates which company was responsible for the production of the electronic control module for which this NAME is being referenced. Manufacturer codes are assigned by committee and may be found in the SAE J1939 base document. See J1939 (top-level document) Appendix B, Table B10. The Manufacturer Code field is not dependent on any other field in the NAME.

4.1.1.11 Identity Number Field

The Identity Number is a 21-bit field in the name assigned by the ECU manufacturer. The Identity Number is necessary in circumstances where it is possible that the NAME would not otherwise be unique (i.e. could be identical). This field should be unique and non-varying with removal of power. This field is necessary to resolve any address contention. The manufacturer must provide this uniqueness among products. It is the manufacturers choice to encode any other information into the identity number, for example, time/date of manufacture, serial number of the module, the vehicle the module is placed into, etc.

4.1.1.12 Dependencies in the NAME Fields

Figure 1 illustrates the dependencies of the upper 128 Functions on Vehicle System and Industry Group. In addition, the dependency of Identity Number on Manufacturer Code is shown. The Reserved field is independent of other fields. Functions 0 through 127 are independent of Industry Group or Vehicle System. Functions 128-254 are dependent on both vehicle system and industry group.

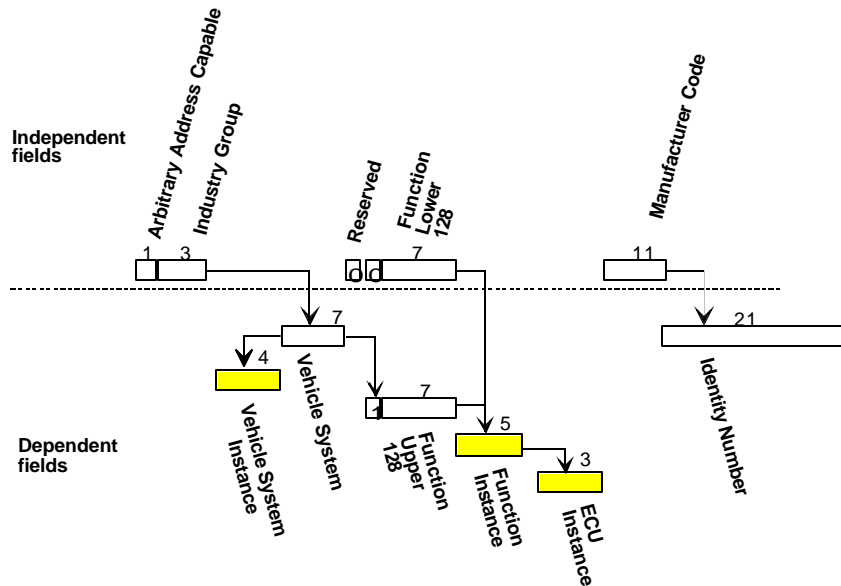

Figure 1. Dependencies in the NAME fields.

#### 4.1.2 Addresses

An address is a one-byte value identifying a particular CA in a network. The address of a CA is incorporated into the identifier of every message sent by that CA and is used to provide uniqueness to messages that are sent by the CA.

Most CAs that operate on a SAE J1939 network will have an assigned preferred address (see SAE J1939, Tables B2-B9) that the CA should attempt to use first. If the CA's preferred address has been successfully claimed (in use) by another CA on the network, the CA will have the option of attempting to secure another source address. Or it may send a Cannot Claim Address message depending on the ECU's addressing capability and the availability of an unused address.

Source addresses must be unique within a particular vehicle or vehicle subnetwork. Source addresses may be associated with different CAs after each power up of the vehicle and may also vary from vehicle to vehicle.

A CA claiming a preferred address in the range 0 to 127 and 248 to 253 must perform the function defined for that preferred address and specify that Function within its NAME. Other CAs may assume that to be the case. The NAME associated with each CA is normally configured during initial vehicle or machine configuration (final vehicle assembly), or when the ECU is added to the vehicle. The NAME, which is associated with a source address, includes identification of the Function a CA serves and retains a consistent definition regardless of the address used.

Five different addressing capabilities are supported in this Recommended Practice. See section 3.3 for details. Support for these addressing capabilities in this standard is not intended to imply that a given CA should support specific capabilities. SAE J1939 CAs are not required to possess a specific addressing capability, however they are required to perform the minimum Network Management functions described in Section 4.5 of this document and may for particular applications be required by the manufacturer to have such capabilities.

Some address capabilities may be better suited to certain CAs than others. For instance, arbitrary addressing capability may be better suited to CAs that may be attached to an already operating network, such as data loggers, calibration ECUs, bridges, or implements. This is due to the possibility of encountering multiple CAs of the same type that can potentially claim the same initial address.

A CA's initial address, the address the CA attempts to claim on first power-up, should be set by the manufacturer to match the list of application-defined preferred addresses wherever possible (SAE J1939 Tables B2-B9). However, a CA's initial address should be reprogrammable to permit an OEM to properly configure a vehicle. Although this may not be necessary on "standard" vehicles, it provides flexibility for applications where multiple instances of a given CA (i.e., when there are two engines, etc.) may exist. This reprogrammability feature is especially important for temporarily connected or aftermarket ECUs.

##### 4.1.2.1 The 254 Address

The network address 254, also known as the NULL address, is only permitted in the Source Address field of the J1939 message identifier and is intended for use only within Network Management communications. See section 4.2

##### 4.1.2.2 The 255 Address

The network address 255, also known as the Global address, is only permitted in the Destination Address field of the J1939 message identifier but never in the Source Address field. See sections 4.2.1 and 4.2.2.

## 4.2 Network Management Procedure

Network management procedures are the messages passed and the actions taken by individual CAs to collectively manage the network. The primary functions of the Network Management protocol are those of Address Management and Network Error Management.

Network Management messages have the same characteristics and requirements as other SAE J1939 messages with the exceptions of the use of the null address. The request for Address Claimed message is a conventional Request message as described in SAE J1939-21. The null address (254) is acceptable in the source address field of a network management message only if the message is a request for Address Claimed or a Cannot Claim Address message. A request directed to the null address (254) yields no responses.

The set of network management messages may be used to request addresses and NAMEs in use by other CAs on the network, claim an address for an ECU, announce the inability to claim an address, or command another CA to assume a new address. Table 4 summarizes the messages.

**Table 4: Address Management Messages**

Message name	PGN	PF	PS	SA	Data Length (Bytes)	Data
Request PG (request for Address Claimed)	59904 (See SAE J1939-21)	234	DA	SA <sup>1</sup>	3	PGN 60928
Address Claimed						
Address Claimed	60928	238	255	SA	8	NAME
Cannot Claim Source Address	60928	238	255	254	8	NAME
Commanded Address	65240	254	216	SA	9 <sup>2</sup>	NAME, new SA

1. Source address could be set to 254 if no address has yet been claimed.

2. Commanded Address message is sent with the Transport Protocol BAM (See SAE J1939-21)

### 4.2.1 Request Message (PGN 59904) for Address Claimed (PGN 60928)

The request message (PGN 59904) for the Address Claimed message (PGN 60928) is used by any CA to request the NAMEs and addresses of CAs in ECUs attached to the network. Upon receipt of the request message for Address Claimed, each CA shall transmit an Address Claimed message containing its address and its NAME. Any CA that is unable to successfully claim an address will respond with a Cannot Claim Address message (4.2.2.2) unless the CA has not yet attempted to claim an address. CAs that have not yet attempted to claim an address should now claim an address. These CAs should not send a Cannot Claim Address message or any other message until an Address Claim has been attempted.

The request message for the Address Claimed message may be sent to any particular address (0-253) or to a global destination address (255). A CA preparing to use a particular address may interrogate that address by sending a request for address claim to that particular address to determine if another CA has claimed it. A CA may determine the existence of a functioning CA with a particular NAME on the network by sending a request for Address Claim to the global address (255) and examining the responses.

The source address for a request for Address Claimed message must be the null address (254) if the request is from a CA that has not yet claimed an address.

A CA should respond to its own request for Address Claimed message if the request was directed to the global address.

#### 4.2.2 Address Claimed / Cannot Claim (PGN 60928)

The Address Claimed PGN may be used in two ways, to claim an address, and to announce that a CA was unable to claim an address. The former case is referred to in 4.2.2.1 as the Address Claimed message, and the latter in 4.2.2.2 as the Cannot Claim Address message. The Address Claimed message is used by any CA to either respond to a received request message for the Address Claimed message or to simply claim a single address on the network. CAs must issue it during initialization of a network or when attaching to a running network. If a CA receives an Address Claimed message claiming its own source address, it should compare the NAME that was received in the Address Claimed message with its own NAME and determine which CA has a higher priority NAME (lower numeric value as described in 4.4.3.3). If the CA receiving the Address Claim determines that it has the higher priority NAME it may then transmit an Address Claimed message containing its NAME and address. However if it has the lower priority NAME it should either attempt to claim a different address or send a Cannot Claim Address message. A CA that loses address arbitration in this manner and is in the process of sending a transport protocol message should immediately cease sending the transport protocol message and should not send a Transport Protocol Abort. Receivers of the transport protocol message must detect the interruption through the normal transport protocol timeout process as specified in J1939-21 (1.25 sec.) Queued transport protocol frames should cease within the timeout and constraints given in J1939-21, 5.10.3.4 (50 ms).

A CA may send the Cannot Claim Address message (See 4.2.2.3) or a Request for Address Claim using the null address as a source address (See 4.2.1) provided it has attempted the address claim and without having successfully claimed an address. A network interconnection CA may not use its own address in communications on the network until it has successfully claimed that address. Handling messages of other CAs is a special case for network interconnection devices. Network interconnection devices acting entirely as repeaters may pass messages bearing the originator's Source Address before claiming their own addresses (For further requirements for network interconnection devices see SAE J1939-31).

Configuration of networks with multiple bridges may create significant delay between transmission and reception of address claims that traverse the bridges. The 250 ms delay may not be adequate in these systems to prevent further arbitration after a CA has successfully claimed an address.

Once a CA has successfully claimed an address, it may begin transmitting other messages on the network and respond to any further Requests for Address Claim.

No valid claim may be made for Address 254, the null address. An Address Claimed message sent with address 254 as the source address is a Cannot Claim Address message (see 4.2.2.2).

The Address Claimed message should always be sent to the global address (255) to provide all ECUs on the network the information to maintain a current address to NAME correspondence. The Address Claimed message should be sent to the global address (255) even when requested in a destination specific message. The Address Claimed message is an exception to the requirements on request messages specified in SAE J1939-21. (SAE J1939-21 defines that a request message that is directed to a specific address be responded to with the destination set to the requester.)

4.2.2.1 Address Claimed Message

Transmission rate:	As required
Data length:	8 bytes
Data page	0
PDU format:	238
PDU specific:	255 (global address)
Default priority:	6
Parameter group number:	60928 (00EE00 <sub>16</sub> )
Source Address	0 to 253 (Address claimed for the Controller Application)

NAME of Controller Application

Byte: 1	Bits 8-1	Least significant byte of Identity Number	See 4.1.1.11
Byte: 2	Bits 8-1	Second byte of Identity Number	See 4.1.1.11
Byte: 3	Bits 8-6	Least significant 3 bits of Manufacturer Code	See 4.1.1.10
	Bits 5-1	Most significant 5 bits of Identity Number	See 4.1.1.11
Byte: 4	Bits 8-1	Most significant 8 bits of Manufacturer Code	See 4.1.1.10
Byte: 5	Bits 8-4	Function Instance	See 4.1.1.8
	Bits 3-1	ECU Instance	See 4.1.1.9
Byte: 6	Bits 8-1	Function	See 4.1.1.7
Byte: 7	Bits 8-2	Vehicle System	See 4.1.1.5
	Bit 1	Reserved	See 4.1.1.6
Byte: 8	Bit 8	Arbitrary Address Capable	See 4.1.1.2
	Bits 7-5	Industry Group	See 4.1.1.3
	Bits 4-1	Vehicle System Instance	See 4.1.1.4

4.2.2.2 NAME of Controller Application

The 8-byte value which uniquely identifies the particular CA that is claiming the associated address.

Data Length:	8 Bytes
Resolution:	See 4.1.1.1
Data Range:	0 to 18446744073709551616
Type:	Measured
Suspect Parameter Number:	2848
Reference:	4.2.2.1 and 4.2.2.3

4.2.2.3 Cannot Claim Address

The Cannot Claim Address message is the same PGN as the Address Claimed message but has a source address of 254, the null address. A Cannot Claim Address message is transmitted by any CA that cannot claim its preferred address and does not have arbitrary addressing capability, or has arbitrary addressing capability but cannot claim an address because none are available for use.

The Cannot Claim Address message may be sent as a response to a Request for Address Claim message. A pseudo-random delay of between 0 and 153 ms should be inserted between the reception of a message triggering the response and the Cannot Claim Address response. The delay is intended to minimize the potential that two Cannot Claim Address messages will cause bus errors. This bus error can occur when two or more Cannot Claim Address messages with identical PGNs and SAs of 254 are sent simultaneously. Differences in the messages will not occur during the arbitration frame, but during the data frame (containing the NAME) where bit checking will force an error frame aborting the message. Therefore, only after the CRC portion of the message will the error frame be asserted, thereby consuming a large number of bit times on the bus. The method for generating the pseudo-random delay is described in 4.4.3.3.

An ECU that cannot claim an address shall not send any message other than the Cannot Claim Address message or a Request for Address Claim.

#### 4.2.3 Commanded Address (PGN 65240)

A network interconnection CA, a bridge for example, or a diagnostic or scan tool may command another CA (Commanded CA) to use a given source address with the Commanded Address Message. The Commanded Address message may be used to instruct a CA with a specific NAME to use a specific source address (Figures A9 and A10 in appendix A). Upon receipt of a Commanded Address message containing its own NAME, a CA should respond in either of two ways: it may accept by initiating an address claim procedure using the new address provided in the Commanded Address message or ignore the command by sending no response. If the commanded address is successfully claimed, future transmissions from the CA should use the commanded address until another Commanded Address message is received or, through power-up or address contention, another address claim process is completed. If the Commanded CA elects to receive the Commanded Address message and cannot change to the commanded address, it should ignore the commanded address. A state transition diagram describing the process for handling a commanded address is presented in Appendix D, Figure D3. Note that if the Commanded CA does not accept the commanded address, an operator or technician may have to modify the CA's source address or NAME through alternate means for the network to operate. If the source address or NAME is modified, the CA must re-issue an Address Claim before originating transmissions on the network. An ECU manufacturer may elect not to accept Commanded Address messages from CAs other than service tools or bridges. Further, ECU manufacturers may require some type of security verification process before accepting a Commanded Address message.

The Commanded Address message contains 9 bytes of data and should be sent using the Broadcast Announce Mode (BAM) of the transport protocol (SAE J1939-21) and should be sent to the global address (255). CAs designed to support the Commanded Address message must also support the BAM form of the Transport Protocol.

##### 4.2.3.1 Commanded Address Message

Transmission rate:	As required
Acknowledgement:	See Figures A9 and A10 in Appendix A
Data length:	9 bytes
Data page:	0
PDU format:	254
PDU specific:	216
Default priority:	6
Parameter group number:	65240 (00FED8 <sub>16</sub> )

NAME of Commanded Address Target



Byte: 1	Bits 8-1	Least significant byte of Identity Number	See 4.1.1.11
Byte: 2	Bits 8-1	Second byte of Identity Number	See 4.1.1.11
Byte: 3	Bits 8-6	Least significant 3 bits of Manufacturer Code	See 4.1.1.10
	Bits 5-1	Most significant 5 bits of Identity Number	See 4.1.1.11
Byte: 4	Bits 8-1	Most significant 8 bits of Manufacturer Code	See 4.1.1.10
Byte: 5	Bits 8-4	Function Instance	See 4.1.1.8
	Bits 3-1	ECU Instance	See 4.1.1.9
Byte: 6	Bits 8-1	Function	See 4.1.1.7
Byte: 7	Bits 8-2	Vehicle System	See 4.1.1.5
	Bit 1	Reserved	See 4.1.1.6
Byte: 8	Bit 8	Arbitrary Address Capable	See 4.1.1.2
	Bits 7-5	Industry Group	See 4.1.1.3
	Bits 4-1	Vehicle System Instance	See 4.1.1.4
Address Assignment			
Byte: 9	Bits 8-1	New source address	See 4.2.3.2

#### 4.2.3.2 NAME of Commanded Address Target

Identifies the particular CA to which the commanded address is being directed.

Data Length:	8 Bytes
Resolution:	See 4.1.1.1
Data Range:	0 to 18446744073709551616
Type:	Measured
Suspect Parameter Number:	2849
Reference:	4.2.3.1

#### 4.2.3.3 Address Assignment (new source address)

This 8-bit field is the 9<sup>th</sup> byte of the data field of the Commanded Address message. It contains the source address that is to be assigned to the CA that has the NAME corresponding to the one conveyed in the first eight bytes of this Commanded Address message. All messages originating from this CA after reception of the Commanded Address message and successful claim of that address shall use that source address.

Data Length:	1 Byte
Resolution:	See 4.1.2
Data Range:	0 to 253
Type:	Measured
Suspect Parameter Number:	2847
Reference:	4.2.3.1

#### **4.2.4 Working Sets**

A Working Set is a concept intended to streamline communications among devices on a network where several applications each with a distinct NAME possibly within different ECU's on different network nodes are acting as distributed processes to create a single function as far as communication is concerned. This is particularly important on an Agricultural Implement Bus where several dissimilar CA's (probably within different ECU's) are intended to co-operate as a single implement or terminal. The Working Set can, for network purposes, allow the use of a single Address as a subset of the "global" destination for one-to-many communications, and to permit the receiver of many-to-one communications to associate each of the many entities with the others that form the particular set. The format for the communications becomes one-to-one

in each case, with the user device sending all data for the Working Set to the address of the network CA that has taken the role of Working Set Master.

All members of the Working Set listen to messages addressed to the Master as though those messages were sent to each member individually. Messages sent by members of the Working Set are associated with the Set (see the example of the Virtual Terminal below) as far as data entry is concerned. The response to a Request by a member of a Working Set will, in general, be sent to the Working Set Master and thus be heard by all of the members of the Working Set. Working Set Masters and Members need to have additional programming that allows for local determination of when messages may be specific to the Master so that programming operations or Fault Table erasure commands are not taken as applying to the entire Working Set.

Initial use of Working Sets will be in the construction and agriculture areas, where the need is for several CA's each within different ECU's to function as the Virtual Terminal. And additionally for several CA's not necessarily within different ECU's upon an implement system (planter for instance) to communicate with the Virtual Terminal in a way that the VT understands that all of those NAMEs are supplying data as a single VT entity. Similarly, a Task Controller may need to command several CA's to take an action. If they are all members of a Working Set, the command sent to the Working Set Master will accomplish the same thing as a series of commands sent to each of the individual CA's in the Set. This will relieve the data link message loading in cases where there is a distribution of functionality and reduce the work required of a controller that needs to send commands or other "destination specific" messages to all of the members of the Working Set.

An example of the need for Working Sets might be a multiple engine electric power generation system where speed change commands might apply to all of the power units. Another example is tractor-trailer combinations where a single command should apply to all of the CA's (regardless of the number of ECU's they reside within) on a given trailer (the trailer Bridge device might be the Master.)

Two message types are needed to define a Working Set. The first is a definition of the set's size; the second identifies the members of the set. All of these messages (the "Working Set Master" defining the Set size, and the series of "Working Set Member" messages giving the NAMEs of all Members except the Master) are transmitted by the Master.

#### 4.2.4.1 Application Notes

##### 4.2.4.1.1 Message sequence

A "Working Set Master" message must always be followed by the appropriate (one less than Working Set size) number of "Working Set Member" messages. A user of the Working Set that does not receive the correct number of Member definitions must request the "Working Set Master" PGN from the Master of the Set. The requirement of the first sentence in this note means that the Master must completely define the Set on receipt of this request.

##### 4.2.4.1.2 Working Set Member Message Spacing

Working Sets will be defined by the NAMEs of the Working Set Members. "Working Set Member" messages should be sent with a spacing of about 100 msec between them. If more than 350 msec elapses after a "Working Set Member" message, the receiver may assume that the Working Set Master believes the list to be complete.

##### 4.2.4.1.3 Compatibility with Conventional Network Processes

Working Set Members are still individual functions on the network, and as such will still communicate as individuals. Fault messages will be sent from the CA's source address (SA), and any commands to clear fault tables, program parameters, etc, will still be addressed to the individual SA of the intended CA in most cases. Working Set Members must be programmed to allow for such individual communications to the Working Set Master without having all of the Member CAs accept programming not intended for them. While it is possible that programming of common data into all Members of the Working Set will be intended, that is not the most likely occurrence and will require that the Member NAME's have application software to allow this to take place.

Applications that do not work with Working Sets may ignore the Working Set messages and communicate directly with all other network devices.

#### 4.2.4.1.4 Constraints on Working Set Membership

Each CA on the network may be a member of at most one Working Set. If an existing Working Set Master issues a new "Working Set Master" message, users of Working Sets on the network must replace the old Working Set definition with the new one. Working Set Masters should accept the responsibility of re-defining their Working Set if they know of needed changes, and may send a "Working Set Master" message with data of zero if the Working Set's purpose is finished. Users of the Working Set should not count on receiving such a message.

#### 4.2.4.1.5 Configuration Changes

A change of the NAME of the Working Set Master will require that it create a new Working Set. The old Working Set will cease to exist but its definition will remain in the memory of the user devices until some clean-up method is exercised. Although it would be convenient if all Working Set Masters cleared their Sets before changing their NAMES, that is not likely to happen at all times. The burden of detecting and correcting problems like duplication of Members is on the user of the Working Set. Users of Working Sets will have to periodically check for duplications and for unused Working Sets in order to recover the internal memory used for those Sets that are no longer active. Note that a change in the Source Address of the Working Set Master will NOT change the definition of the Set. Users should update the association of SA to NAME when the new Address Claim is received, and Members must change the address through which they expect to receive Working Set communications.

#### 4.2.4.1.6 Source Address Changes

A change in the Source Address of a Working Set Member will result in the need for the users of Working Sets to associate the new SA with the appropriate Working Set. Since the Working Set Members are defined by NAME, the SA change (assuming that the NAME is unchanged) can be handled by the Working Set users as they receive new Address Claim messages.

#### 4.2.4.1.7 Missing Working Set Members

A Working Set may be created with Members included that are not currently on the network. Users should create the Working Set with the total number of Members as specified, and add the SA of members as they claim addresses. This process differs little from the above process of changing the SA of a Member that is active but which changes SA due to a later address claim by another device. In such a case it is the responsibility of the Working Set Master to know the NAMES of all of the potential Members of the Working Set. Alternatively, the Master can revise the Working Set definition when the new Member joins the network.

The term "user" in these notes is intended to mean a controller application (CA) that understands Working Sets and knows how to communicate with the Set as a separate entity. It is not a member of the set being described, but is not prohibited from being a Member (or Master) of another Working Set.

4.2.4.2 Working Set Master Message – WSMSTR (PGN 65037)

This message is sent by the Master of a Working Set to identify how many members there are in said set. The Master counts as a member in the total. The source address of this message should be the Master's NAME. Also particular Working Sets may be identified by their Master's NAME.

Transmission rate: As required  
 Data length: 8 bytes  
 Data page: 0  
 PDU format: 254 PDU2 Global  
 PDU specific: 13  
 Default priority: 7  
 Parameter group number: 65037 (FE0D<sub>16</sub>)

Number of Members			
Byte: 1	Bits 8-1	Number of Members in Working Set	See 4.2.4.3
Bytes 2-8:		reserved	

4.2.4.3 Number of Members

Provides the count of the number of members in a particular Working Set. The particular Working Set is identified by the NAME of the Working Set Master, which is associated with the Source Address of the message containing this parameter. No member (as identified by a specific NAME) may belong to more than one Working Set at a time.

Data Length: 1 Byte  
 Resolution: 1 member  
 Data Range: 2 to 250 (minimum of 2 members in a working set and a maximum of the limit of nodes in the J1939 network)  
 Type: Measured  
 Suspect Parameter Number: 2409  
 Reference: 4.2.4.2

4.2.4.4 Working Set Member Message – WSMEM (PGN 65036)

This message is sent by the Master of a Working Set to identify an individual member of a specific Working Set (Master's Source Address identifies the particular Working Set). There will be a number of these messages sent by any particular Master. The number of messages will be one less than the number of members in the Working Set. No message is required to identify the Master's NAME. This may be obtained from the Master's Address Claim. This message structure requires that units communicating with a Working Set must verify that they have received the appropriate number of Working Set Member messages so that they can identify all of the members of the particular Working Set.

Transmission repetition rate: As required  
 Data length: 8 bytes  
 Data page: 0  
 PDU format: 254 PDU2 Global  
 PDU specific: 12  
 Default priority: 7  
 Parameter group number: 65036 (FE0C<sub>16</sub>)

NAME of Working Set Member	NAME of this specific member of the Working Set identified by the source address of this message.	
Byte: 1 Bits 8-1	Least significant byte of Identity Number	See 4.1.1.11
Byte: 2 Bits 8-1	Second byte of Identity Number	See 4.1.1.11
Byte: 3 Bits 8-6	Least significant 3 bits of Manufacturer Code	See 4.1.1.10
Bits 5-1	Most significant 5 bits of Identity Number	See 4.1.1.11
Byte: 4 Bits 8-1	Most significant 8 bits of Manufacturer Code	See 4.1.1.10
Byte: 5 Bits 8-4	Function Instance	See 4.1.1.8
Bits 3-1	ECU Instance	See 4.1.1.9
Byte: 6 Bits 8-1	Function	See 4.1.1.7
Byte: 7 Bits 8-2	Vehicle System	See 4.1.1.5
Bit 1	Reserved	See 4.1.1.6
Byte: 8 Bit 8	Arbitrary Address Capable	See 4.1.1.2
Bits 7-5	Industry Group	See 4.1.1.3
Bits 4-1	Vehicle System Instance	See 4.1.1.4

#### 4.2.4.5 NAME of Working Set Member

The identifier of the particular CA that is a member of the Working Set identified by the source address of this message. This parameter is a NAME with the format described in 4.1.1.

Data Length:	8 Bytes
Resolution:	See 4.1.1.1
Data Range:	0 to 18446744073709551616
Type:	Measured
Suspect Parameter Number:	2845
Reference:	4.2.3.1

### 4.3 Network Error Management

Network Error Management exists to provide a means of detecting addressing related errors, for example, failure of a CA to successfully claim an address. Other addressing related errors, for example duplicate address claims or duplicate NAMES may be detected by a diagnostic tool through the use of the request for address claim capability.

#### 4.3.1 Cannot Claim Address

If a CA has attempted and cannot successfully claim a source address because the address(es) it attempted to claim are already claimed on the network by a CA with a higher priority NAME, a Cannot Claim Address error exists. Service tools, and bridges in some systems, may be expected to detect and resolve failures to claim an address. Service tools may monitor the Cannot Claim Address message and report the problem to the operator of the tool

#### 4.4 Address Claim and CA Initialization procedure

The Address Claimed message is used by each CA to acquire a unique address on the vehicle network after completing its own Power On Self Test (POST) and before originating other communications messages. Successful claiming of an address by a CA consists of sending an Address Claim message for the address to be claimed and not receiving contending claims for that address. Single Address CAs with addresses in the 0-127 and 248-253 ranges may begin regular network communications immediately after sending the address claim message. Other CAs should not begin or resume origination of normal network

traffic until 250 ms after claiming an address (See Figure A1) to allow contending claims to be made before the address is used.

The procedure below assures that any duplicate addresses are detected during initialization processes and resolved at that time.

#### **4.4.1 Address Claim Prioritization**

In the event that two CAs contends for an address, priority shall be allotted to the CA with the lowest numerical value of the NAME. The NAME should be treated as a single 8-byte numerical value. For determination of value, the Arbitrary Address Capable bit should be considered the most significant bit. For example, should Engine 0 and Engine 1 both desire the same address, Engine Instance 0 will have a lower absolute value NAME and therefore will win address arbitration. This process is shown in Figures A2 and A3 in Appendix A.

Although this requires comparison of the 8-byte NAMEs in the Address Claimed Message data fields, it eliminates ambiguity in the address claiming process.

#### **4.4.2 Address Claim Requirements**

Every CA is required to claim its source address upon initialization and upon any change of the CA's NAME or source address. A CA may support and act on a Commanded Address message, in which case, the later requirement provides confirmation that the Commanded Address message was accepted. The requirement also assures that each CA takes responsibility for obtaining a valid address and that other CAs properly arbitrate for the address if the CA has not yet heard their address claim.

The destination address for an address claim should be global (255) to "announce" the claim message to all CAs on the network.

A CA that is configured to receive messages that it transmits should be able to differentiate between Address Claimed messages received from itself and those received from other CAs. This capability is necessary to allow duplicate addresses to be detected.

##### 4.4.2.1 Requirements for Requests for Address Claimed

The source address for a Request for Address Claimed message must be the null address (254) if the request is from a CA that has not yet successfully claimed an address.

#### **4.4.3 Address Claim Initialization Rules**

The following rules apply to all CAs (minimum requirements):

##### 4.4.3.1 Response to a Request for Address Claimed sent to the global address

A CA should always respond to a Request for Address Claimed directed to the global address with either an Address Claimed message or if the CA has not been successful in claiming an address, a Cannot Claim Address message.

##### 4.4.3.2 Response to a Request for Address Claimed sent to a specific address

A CA should always respond to a Request for Address Claimed where the destination address of the request is the CA's address. The response to the request, the Address Claimed message, should be sent to the global address (255).

#### 4.4.3.3 Response to Address Claims of Own Address

A CA should transmit an address claim if it receives an address claim with a source address that matches its own, and if its own NAME is of a lower value (higher priority, see 4.4.1) than the NAME in the claim it received. If the CA's NAME is of a higher value (lower priority, see 4.4.1) than the NAME in the claim it received, the CA should not continue to use that address. (It may send a Cannot Claim Address message or it may attempt to claim a different address.)

#### 4.4.3.4 Contention for an Address

A CA that discovers it cannot use an address due to a higher priority competing claim, should either send a Cannot Claim Address message (Non-configurable, Service configurable, or Command configurable) or select another address and attempt to claim that address (Self-configurable and Arbitrary Address Capable). A CA previously communicating to this CA should detect that the CA has become disabled or changed its address by monitoring the Address Claim by the more dominant CA (lower name value) as well as by monitoring the Cannot Claim Address message.

### **4.4.4 Message Sequences for Initialization**

Graphical schematics of the initialization sequences for the different CAs under the various potential conditions are provided in Figures A1 to A7 in Appendix A. The conditions, under which each figure applies, are specified in the paragraphs below. The address and NAME prioritization process used in the figures is presented in 4.4.1. State transition diagrams describing address claiming processes are presented in Appendix D, Figures D1, D2, and D3.

#### 4.4.4.1 Message sequences for initialization for all CAs on the network

Message sequences for initialization of all CAs using the network are shown in Appendix A, Figures A1, A2, A3 and A4. The condition under which the sequence applies is summarized in the table below.

Figure	Condition under which sequence is applicable
A1	CA with address claim and no contention.
A2	Two Single Address CAs Attempt To Claim the Same Address But Not Simultaneously
A3	CA where NAME A is less than NAME B and CA B is Self Configurable or Arbitrary Address Capable
A4	Two CAs Attempting To Claim The Same Address Simultaneously.

#### 4.4.4.2 Potential Identical Identifiers in Network Management Messages

The possibility exists for messages with the same identifiers to be generated by different CAs with three of the network management messages. These messages are 1) request for Address Claimed, 2) Address Claimed, and 3) Cannot Claim Address messages.

- 1) The sending of a Request for Address Claimed message simultaneously by two different CAs that are both sending from the null address (254) is not a problem because the data field is the same for both messages.
- 2) The sending of an Address Claimed message simultaneously by two different CAs, which are contending for the same address, will cause bus collisions because the NAMEs in the data field of the message will be different. See 4.4.3.3 for the resolution method.
- 3) The sending of a Cannot Claim Address message simultaneously by two different CAs from address 254 will cause bus collisions because the NAMEs in the data field will be different. See section 4.4.3.3 for the resolution method.

#### 4.4.4.3 Address Claim Bus Collision Management

If multiple CAs have the same address and different NAMEs, simultaneous Address Claimed messages will result in bus errors. To minimize the probability of modules generating bus errors until going bus off, the following special processing should be used when transmitting claim messages.

After transmitting any claim message, the transmitting CA should monitor error code information. If the error code indicates that a bus error has occurred, any automatic retransmission attempts by the CAN peripheral should be canceled if possible.

The re-transmission of the claim message should be re-scheduled after end of frame plus a transmit delay.

The transmit delay will be calculated to produce a pseudo-random value between 0 and 255. The NAME, serial number or other unique information within the CA should be selected by the manufacturer to seed the pseudo-random number generator. The transmit delay will be added to the normal idle period before the next claim message is transmitted. The module should be able to schedule the next claim message within  $\pm 0.6$  ms of the calculated delay.

The delay will be calculated by multiplying the 0 to 255 output of the pseudo-random number generator by 0.6 ms (The maximum time one message requires on the bus) producing a delay range of 0-153 msec. If a second claim message transmission results in a bus error, the process should be repeated with a new pseudo-random number.

Figure A4 in Appendix A illustrates the process of simultaneous claims by two CAs of the same address.

#### 4.4.4.4 A CA which is Unable to Successfully Obtain an Address.

The message sequence for answering a request for Address Claimed by a CA that is unable to successfully obtain an address is shown in Figure A8. The CA should respond to a request for Address Claimed with a Cannot Claim Address message after a transmit delay (See Section 4.4.4.3.) In the case where there is a collision of the Cannot Claim Address messages, the process in 4.4.4.3 should be used. A CA that is unable to successfully claim an address shall send no messages except:

- 1) A Cannot Claim Address message in response to requests for Address Claimed or to respond to a Commanded Address message, or
- 2) A request for Address Claimed message.

#### **4.4.5 Requests for Address Claimed for Self-Configurable Addressing CAs**

A Self-Configurable Addressing or Arbitrary Address Capable CA may elect to obtain a list of the addresses already claimed on the network before itself claiming an unused address. Note that the CA may, upon discovery that its preferred address has been claimed, request the addresses of all CAs on the network using the source address of 254 and then claim an address that was not previously claimed. Preferably, a Self-Configurable Addressing or Arbitrary Address Capable CA will transmit a request for Address Claimed with a destination address set to the preferred address it would like to claim for the purpose of finding an unclaimed address. The Address Request sent to the global address should be used with care since it generates a response from every CA on the network (Appendix A, Figure A6). The specific request can be directed at an address that is not likely to be occupied and will minimize message traffic (Appendix A, Figure A5).



#### 4.4.5.1 Technical Note Regarding Multiple Self-Configurable Addressing CAs

Special care should be taken in the design of arbitrary address capable CAs if more than one of a manufacturer's ECUs may be connected in a system. These CAs may have the same initialization algorithm and may issue simultaneous initial Address Claimed messages. If these CAs attempt to claim the same address, a bus-OFF condition is likely to occur. Manufacturers should design CAs of this type to minimize the probability that they issue initial address claims at the same time. Alternatively manufacturers may design CAs of this type to minimize the probability that the CAs initially claim the same addresses. The use of both of these techniques would significantly improve (shorten) initialization time.

#### 4.4.5.2 CAs Not Permanently Connected to the Network.

A request for Address Claimed message may be used to determine if an address is being used before attempting to claim that address. This process allows an arbitrary address capable device to create less address contention when it initializes on the network. This procedure is appropriate for CAs that are not permanently connected to the network, such as tools. Message sequences for initialization of CAs not permanently connected to the network are shown in Appendix A, Figures A5, A6 and A7. The request for Address Claimed message preceding the claim can be used in identifying an unused address for CAs that are arbitrary address capable.

#### **4.4.6 Construction of Address to NAME Association Tables**

Request for Address Claimed sent to specific addresses or to the global address may be used to construct an address to NAME association table. This table may be used in some CAs to confirm the associations for critical functions, for example, to confirm that the powertrain engine is located at address 0 to insure that torque/speed control messages from the transmission are sent to the proper destination. In CAs where a small number of address to NAME associations are required, Requests for Address Claimed sent to a specific address should be used. In a diagnostic tool where all of the CAs on a network need to be inventoried, a Request for Address Claimed sent to the global address is appropriate.

### **4.5 Minimum Network Management Functionality**

The features provided by the Network Management protocol include more than the minimum required for a CA communicating on a SAE J1939 network. The minimum network procedures are those without which a CA cannot operate on a SAE J1939 network. They are described in the following clauses.

#### **4.5.1 Reaction to Power Supply and Other Related ECU Disturbances**

Due to the questionable integrity of power supplied to ECUs on towed vehicles and the time required for address re-arbitration, the following criteria are established. This applies to all ECUs that are powered through a tractor interface connector on a towed subnetwork (corresponding to a breakaway connector for the agricultural industry group). Any disturbance, such as momentary power loss that lasts less than a specified time (2 ms minimum, 10 ms recommended) should not result in network re-initialization (a new round of address claim). This does not preclude a CA from performing any degree of reset or re-initialization within the CA. The CA must retain its NAME, address, and any NAME/address tables used by that CA through such a disturbance. For disturbances of longer duration or higher frequency, network re-initialization may be performed and is required if the disturbance is longer than 1 second. The required re-initialization after 1 second is needed to force towed vehicle systems to reinitialize after reconnection to the towing vehicle.

There is no requirement for towing vehicles.

#### 4.5.2 Minimum Network Management Capability

The following section describes minimum network management capability for CAs to operate on a SAE J1939 network. These are in addition to the minimum requirements listed in section 4.4.3. A summary of the requirements and capabilities for SAE J1939 CAs is provided in Appendix B.

##### 4.5.2.1 Request for Address Claimed Message

Upon receipt of a Request for Address Claimed message, a CA must transmit an Address Claimed message. This message will contain its current address if it has already successfully claimed, its proposed address if it has not yet attempted a claim, or the NULL address if it has tried to claim an address and failed. CAs that have not yet attempted to claim an address should not participate in network communications until the CA has attempted to claim an address. These CAs should not send a Cannot Claim Address message or any other message until an Address Claim has been attempted.

Note that a CA should also respond to its own request for Address Claimed message.

##### 4.5.2.2 Address Claimed Message before Using a Source Address

No CA may originate a message on the network until it has successfully claimed an address (see section 4.2.2) with these exceptions:

1. The CA may transmit a Request for Address Claimed using the null address as a source address.
2. The CA must respond to a request for Address Claimed message directed to the global address (255) by transmitting its claim: see Section 4.5.2.1 for details.
4. A network interconnection device acting entirely as a repeater may pass messages bearing the Source Address of the originator before claiming its own address (For further requirements for network interconnection devices see SAE J1939-31).

Once a CA has successfully claimed an address, it may respond to a Request for Address Claimed and immediately resume transmitting other messages on the network.

If the source address or NAME of a CA is modified, (for example, through the Commanded Address message or through proprietary techniques) the CA must re-issue an Address Claim before originating transmissions on the network.

##### 4.5.2.3 Disruption of the Network During Connection or Disconnection of an ECU

Connection, disconnection, or power-up of the ECU should not disrupt network communications. Disruption of the network would consist of uncontrolled transmission of a bit stream to the network during the power-up of an ECU.

##### 4.5.2.4 Continuity of Addresses Across Power-down and Power-up Cycles

CAs should be able to maintain their source address and any addresses for CAs that are communicated with so that the CA can attempt to use the same addresses at the next power-up. This should be done except in cases where special requirements override this recommendation, for example in towed subnetworks of On-Highway trailers where the instance and associated addresses of the trailer may change at each power-up, for example, when changing trailers.

**PREPARED BY THE SAE TRUCK AND BUS CONTROL AND COMMUNICATIONS SUBCOMMITTEE OF  
THE SAE TRUCK AND BUS ELECTRICAL AND ELECTRONICS COMMITTEE**

**Appendix A: Initialization Sequence Timing Diagrams**

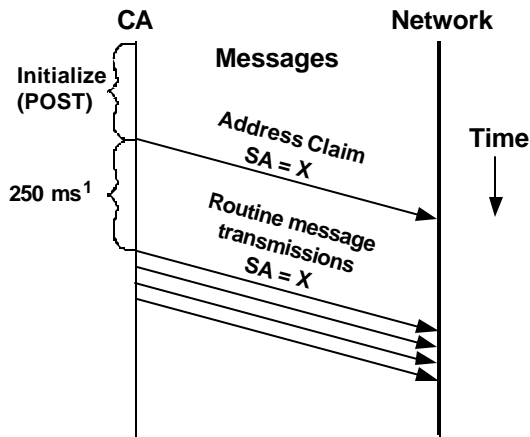

<sup>1</sup>Single Address CAs with addresses in the 0-127 and 248-253 ranges may omit the 250 ms delay.

FIGURE A1 - Initialization of A CA with Address Claim and No Contention

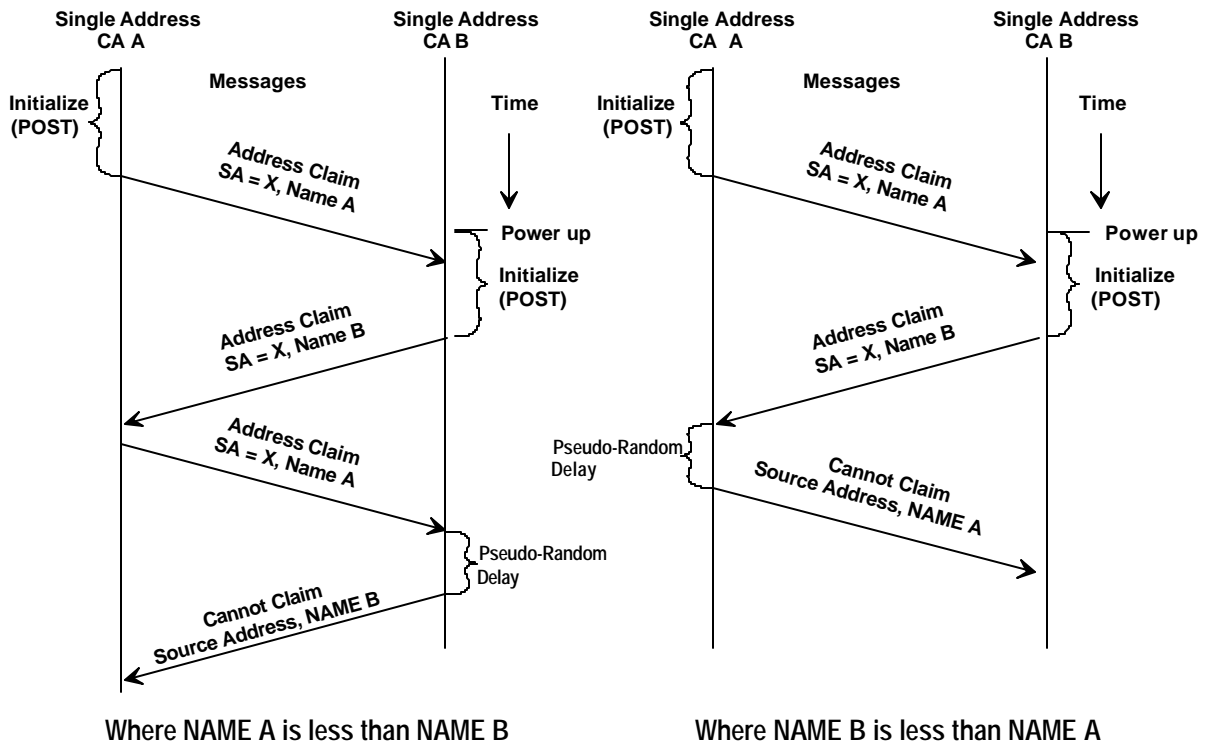

FIGURE A2 - Initialization of an ECU Where Two Single Address CAs Attempt To Claim the Same Address But Not Simultaneously

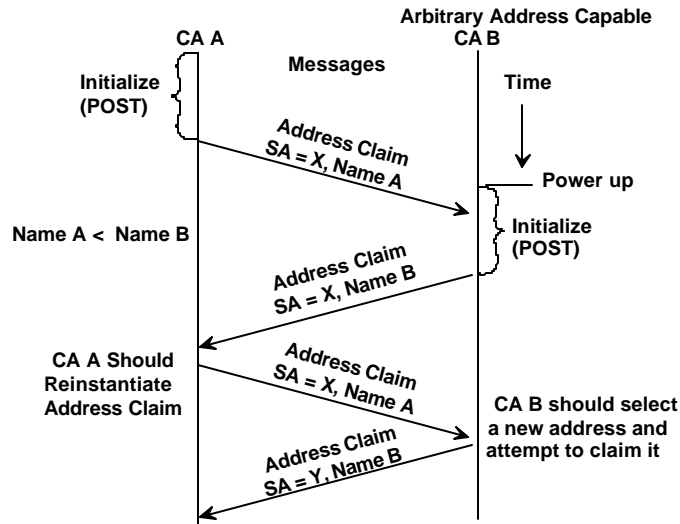

FIGURE A3 - Initialization of a CA Where NAME A Is Less Than NAME B and CA B is Arbitrary Address Capable

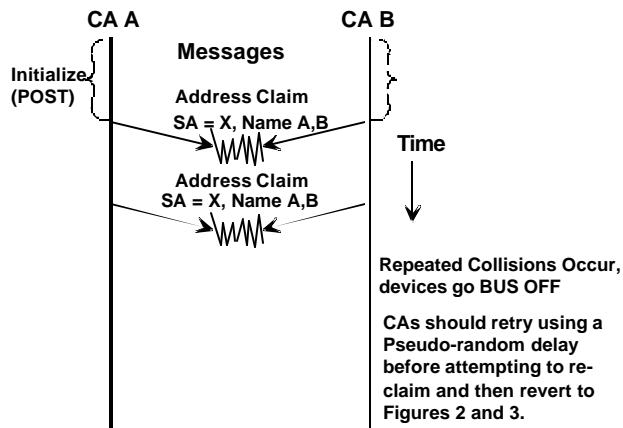
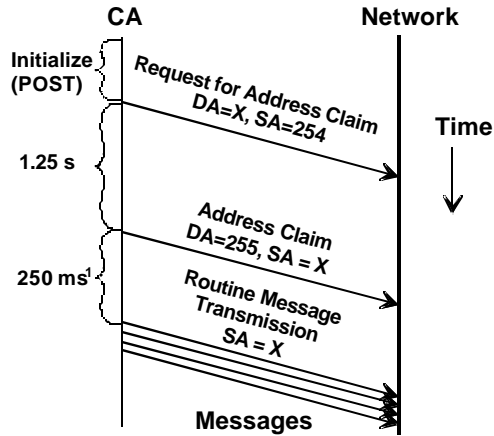
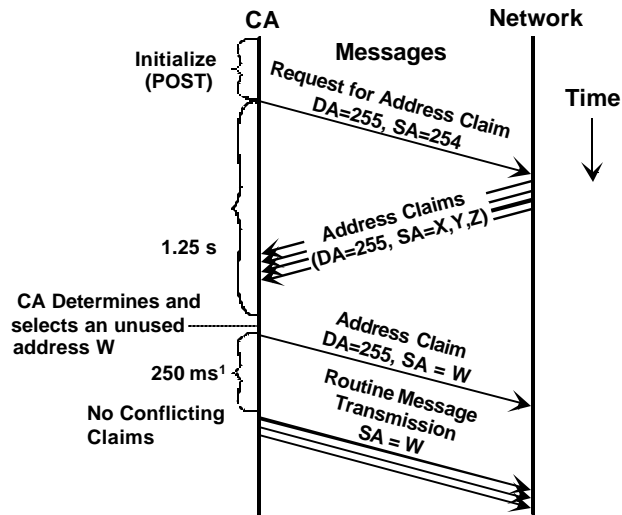

FIGURE A4 - Initialization of a CA with Two CAs Attempting to Claim the Same Address Simultaneously



<sup>1</sup>Single Address CAs with addresses in the 0-127 and 248-253 ranges may omit the 250 ms delay.

FIGURE A5 - Initialization of an Arbitrary Address Capable CA with No Contention



<sup>1</sup>Single Address CAs with addresses in the 0-127 and 248-253 ranges may omit the 250 ms delay.

FIGURE A6 - Initialization of an Arbitrary Address Capable CA with a Request for Address Claimed Sent to the Global Address

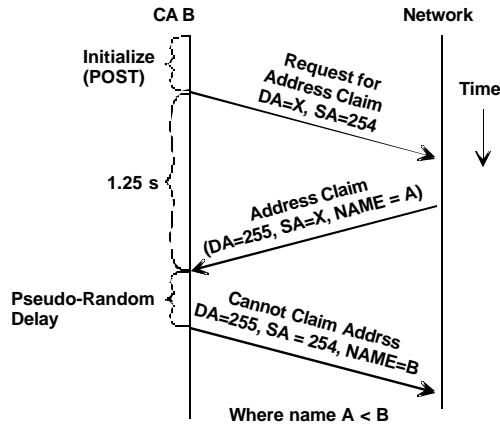

FIGURE A7 - Initialization of a Single Address CA with a Request for Address Claimed Where Address Is In Use

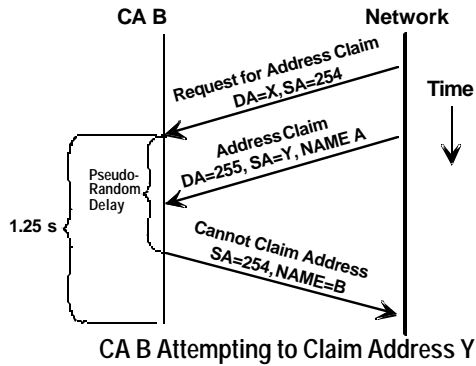

FIGURE A8 - Response to a Request for Address Claimed by a CA which has Been Earlier Unsuccessful In Claiming an Address.

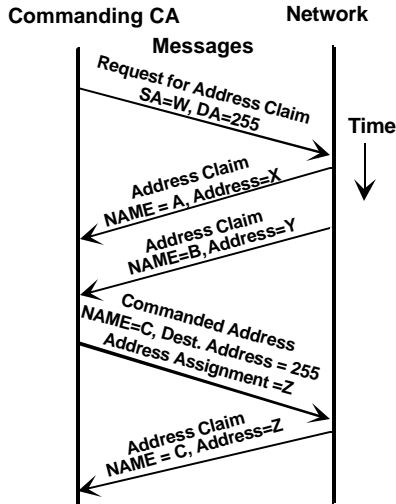

FIGURE A9 - Commanding an Address of a CA which does not have an Address and Supports the Commanded Address Message

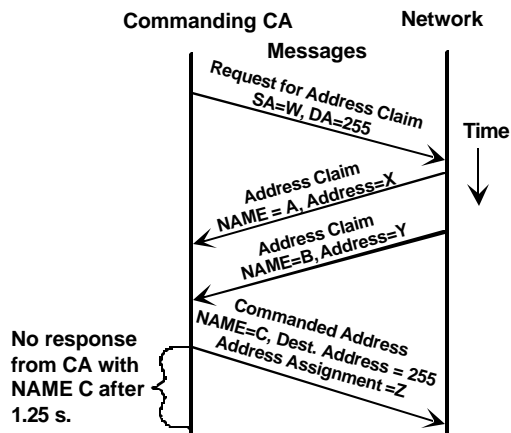

FIGURE A10 - Commanding an Address of a CA which does not have an Address and the Commanded CA Does Not Support A Commanded Address Message

(Note: the commanded ECU may elect not to support the Commanded Address message in which case, the Commanded Address message will be ignored.)

**Appendix B Summary of Requirements and Capabilities of CAs**

Note: Other than the required categories (R), the classifications are provided for general guidance only.

Capability	Standard					Diagnostic / Development Tools					Network Interconnection				
	Non-Configurable	Service-Configurable	Command Configurable	Self-Configurable	Arbitrary Address Capable	Non-Configurable	Service-Configurable	Command Configurable	Self-Configurable	Arbitrary Address Capable	Non-Configurable	Service-Configurable	Command Configurable	Self-Configurable	Arbitrary Address Capable
<div style="border: 1px solid black; padding: 5px;">                     Key:                      R - Required                      D - Desirable                      P - Permissible                      N - Not recommended or required                      NA - Not Applicable                 </div>															
Issue a Valid Address Claimed Message before using a Source Address (4.5.2.2)	R	R	R	R	R	R	R	R	R	R	R	R	R	R	R
Upon receipt of a request for Address Claimed message, an CA should transmit an Address Claimed or a Cannot Claim SA Message (4.5.2.1)	R	R	R	R	R	R	R	R	R	R	R	R	R	R	R
Name retained across power up cycle (4.1)	R	R	R	D	D	R	R	R	D	D	R	R	R	D	D
Address retained across power up cycle (4.5.2.4)	R	R	R	D	D	R	R	R	D	D	R	R	R	D	D
Name field programmability (4.1.1)	NA	D	D	D	D	NA	D	D	D	D	NA	D	D	D	D
Address table retained across powerup (4.5.2.4)	P	P	P	D	D	P	P	P	D	D	P	P	P	D	D
Support Commanded Address Message Containing Own NAME (4.2.3)	NA	P	R	P	P	NA	D	R	D	D	NA	D	R	D	D
Support transmission of Commanded Address Message (4.2.3)	P	P	P	P	P	D	D	D	D	D	P	P	P	P	P
Send Request for Address Claim before attempting to claim (4.4.5)	P	P	P	P	P	D	D	D	D	D	P	P	P	P	D
Address configuration capability (3.3)	P	P	P	P	P	N	P	D	D	D	P	P	P	P	P
Monitor and correct situations where CAs cannot claim addresses (4.2.3)	N	N	N	N	N	D	D	D	D	D	P	P	P	P	P

FIGURE B1 - Summary of Requirements and Capabilities of CAs



## Appendix C NAME Examples

### C.1 NAME Examples

Three examples of the NAMEs are shown below, ranging from a very simple case to a very complex case. Due to the nature of the naming convention, NAMEs in these examples are expressed in binary. Appendix B of SAE J1939 should be used as a source when constructing a NAME. For questions about the individual fields of the NAME, refer to Section 4.1.1 & Table 1 in this document.

#### C.1.1 A Single ECU with a CA Serving an Engine on an On-Highway Heavy-Duty Truck.

From Appendix B, Table B1 of SAE J1939, the Industry Group for this application is On-Highway that has an Industry Group value of 1. (Had the specific application not been identified it would have been correct to place an engine controller within the Global, applies to all, Industry Group.) For a tractor in Industry Group 1, the Vehicle System value is 1 from Appendix B, Table B12 of SAE J1939. The Vehicle System Instance is 0 since there is only one and therefore it must be the first instance. From the pointer to table B11, we find engines are to have a Function value of 0. As this is a single-engine vehicle, the Function Instance value is also set to 0. Since there is only one ECU, the ECU Instance value is 0. The Manufacturer Code, and the Identity Number bits are shown in a generic form. This yields the ECU name as shown in Figure C1:

Arbitrary Address Capable	Industry Group	Vehicle System Instance	Vehicle System	Reserved	Function	Function Instance	ECU Instance	Mfg. Code	Identity Number
1 bit 0	3 bit 001	4 bit 0000	7 bit 0000001	1 bit 0	8 bit 00000000	5 bit 00000	3 bit 000	11 bit mm...m	21 bit ii...i

FIGURE C1 – Example NAME for a Single ECU with a CA Serving an Engine on an On-Highway Heavy-Duty Truck

#### C.1.2 Brakes on the second trailer of heavy-duty truck.

This example illustrates NAME assignment for a single ECU with a single CA that has Single Address capability and is serving as a brake controller on the second trailer of heavy-duty truck. From Appendix B, Table B1 of SAE J1939, the Industry Group for this application is On-Highway and has an Industry Group value of 1. The Vehicle System Name value for a trailer is 2, which is found in Appendix B, Table B12 of SAE J1939 under the On-Highway Industry Group. The Vehicle System Instance is 1 for the second Instance of trailer. Brake Controller CAs on a trailer are identified as a "Brakes - System Controller" and have a Function value of 9. Assuming this is the only Brake controller on the trailer, the Function Instance value is set to 0. Since there is only one ECU for this ABS CA, the ECU Instance value is 0. The Manufacturer Code, and the Identity Number bits are again shown in a generic form. See Figure C2.

Arbitrary Address Capable	Industry Group	Vehicle System Instance	Vehicle System	Reserved	Function	Function Instance	ECU Instance	Mfg. Code	Identity Number
1 bit 0	3 bit 001	4 bit 0001	7 bit 0000010	1 bit 0	8 bit 00001001	5 bit 00000	3 bit 000	11 bit mm...m	21 bit ii...i

FIGURE C2 – Example NAME for an ABS on the Second Trailer of Heavy-Duty Truck

**C.1.3 Agricultural planters with separate Section Controls.**

This example illustrates NAME assignment for two agricultural planters connected together in a system with separate Section Control on eight individual sections, each section with two ECUs. From Appendix B, Table B1 of SAE J1939, the Industry Group for this application is Agricultural Equipment and has an Industry Group value of 2. For a planter in this Industry Group, the Vehicle System Name value is 4 from Appendix B, Table B12 of SAE J1939. Since this is an agricultural implement, self-configurable or arbitrary addressing should be used. This example assumes the CA is arbitrary address capable, thus the Arbitrary Address Capable bit is set to 1. Since there are two planters, the Vehicle System Instances would be 0 for CAs on planter 1 and 1 for CAs on planter 2. Since the CA's Function is Section On/Off Control, the Function Name value is 129. The Function Instance field would run from 0 to 7 on each of the planters to identify row 1 through 8. Since there are two ECUs per section, the ECU instances of 0 and 1 would occur for each of the eight Function values. The Manufacturer Code, and the Identity Number bits are shown in a generic form. The resulting NAMES are shown in Figure C3:

	Arbitrary Address Capable	Ind. Group	Vehicle System Instance	Vehicle System	Reserved	Function	Function Instance	ECU Instance	Mfg. Code	Identity Number
	1 bit	3 bit	4 bit	7 bit	1 bit	8 bit	5 bit	3 bit	11 bit	21 bit
	1	010	No.	Planter	0	Section Control	No.	No.	mm...m	Mfg. Assigned
Planter '1', Section '1', ECU '1'	1	010	0000	0000100	0	10000001	00000	000	mm...m	ii...i
Planter '1', Section '1', ECU '2'	1	010	0000	0000100	0	10000001	00000	001	mm...m	ii...i+n
Planter '1', Section '2', ECU '1'	1	010	0000	0000100	0	10000001	00001	000	mm...m	ii...i+p
Planter '1', Section '2', ECU '2'	1	010	0000	0000100	0	10000001	00001	001	mm...m	ii...i+q
...	...	...	...	...	...	...	...	...	...	...
Planter '2', Section '8', ECU '1'	1	010	0001	0000100	0	10000001	00111	000	mm...m	ii...i+r
Planter '2', Section '8', ECU '2'	1	010	0001	0000100	0	10000001	00111	001	mm...m	ii...i+s

FIGURE C3 – Example NAMES for Agricultural Planters with Separate Section Controls

***Appendix D: State Transition Diagrams for Address Claiming Processes***

State transition diagrams are presented in Figures D1, D2, and D3 for address claiming processes. Processes are presented for initialization of both single address capable and arbitrary address capable ECUs. These diagrams are intended to clarify processes outlined throughout this specification. The specifications in the paragraphs of this document have precedence in the event of any discrepancy between the text and figures.

States are shown in the diagrams as circles with the title of the state enclosed in the circle. Arrows leaving the states have associated text describing the event that triggers transition from the state. The triggering event text is followed by a slash (/). In some cases, there is an action that takes place after the trigger on entering the next state. The transition action is associated with the arrows leaving a state and is text that is not followed by a slash (/).

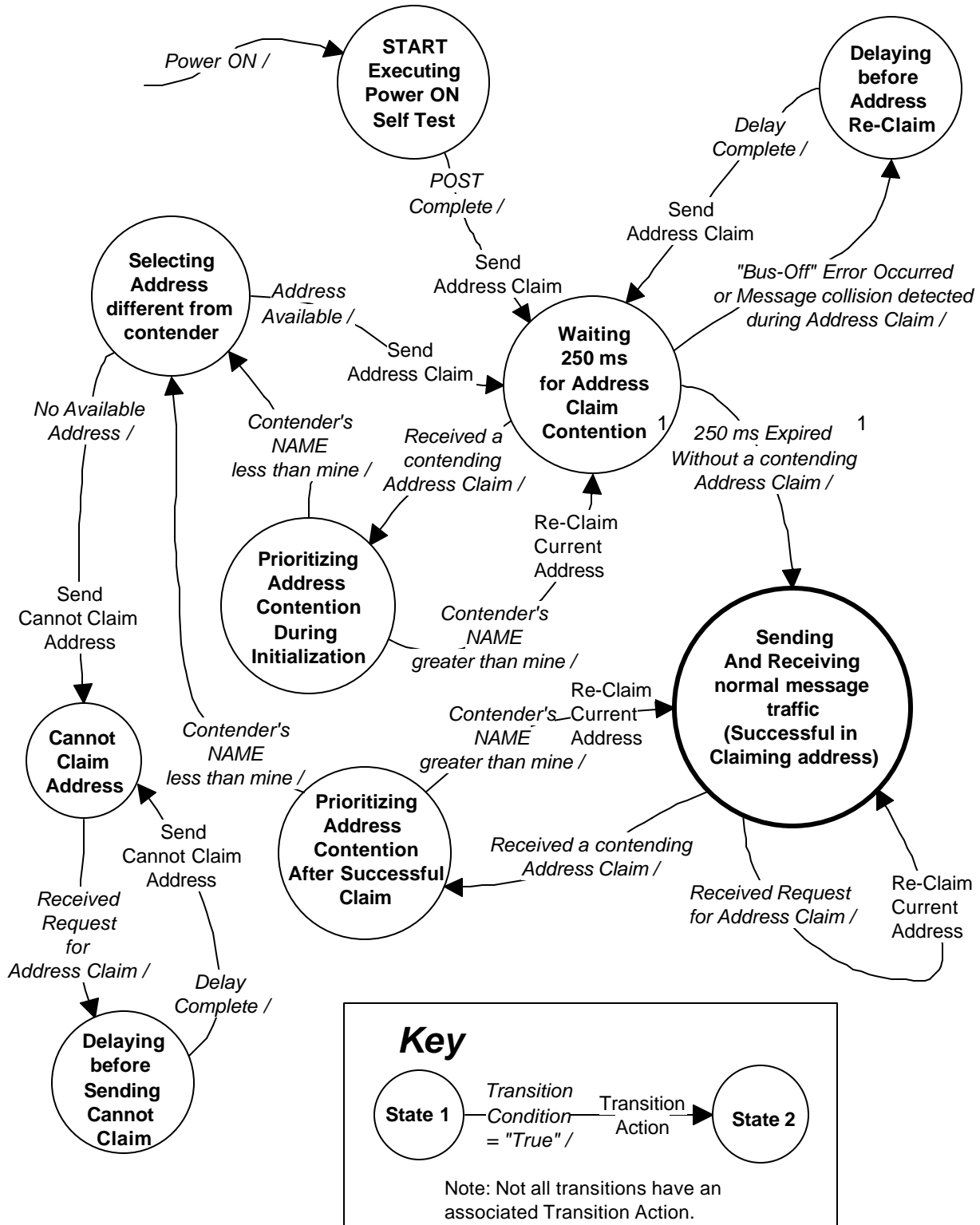

<sup>1</sup> CAs claiming addresses in the 0-127 and 248-253 ranges may omit the 250 ms delay.  
 FIGURE D1 - State Transition Diagram for Initialization of Arbitrary Address Capable CAs

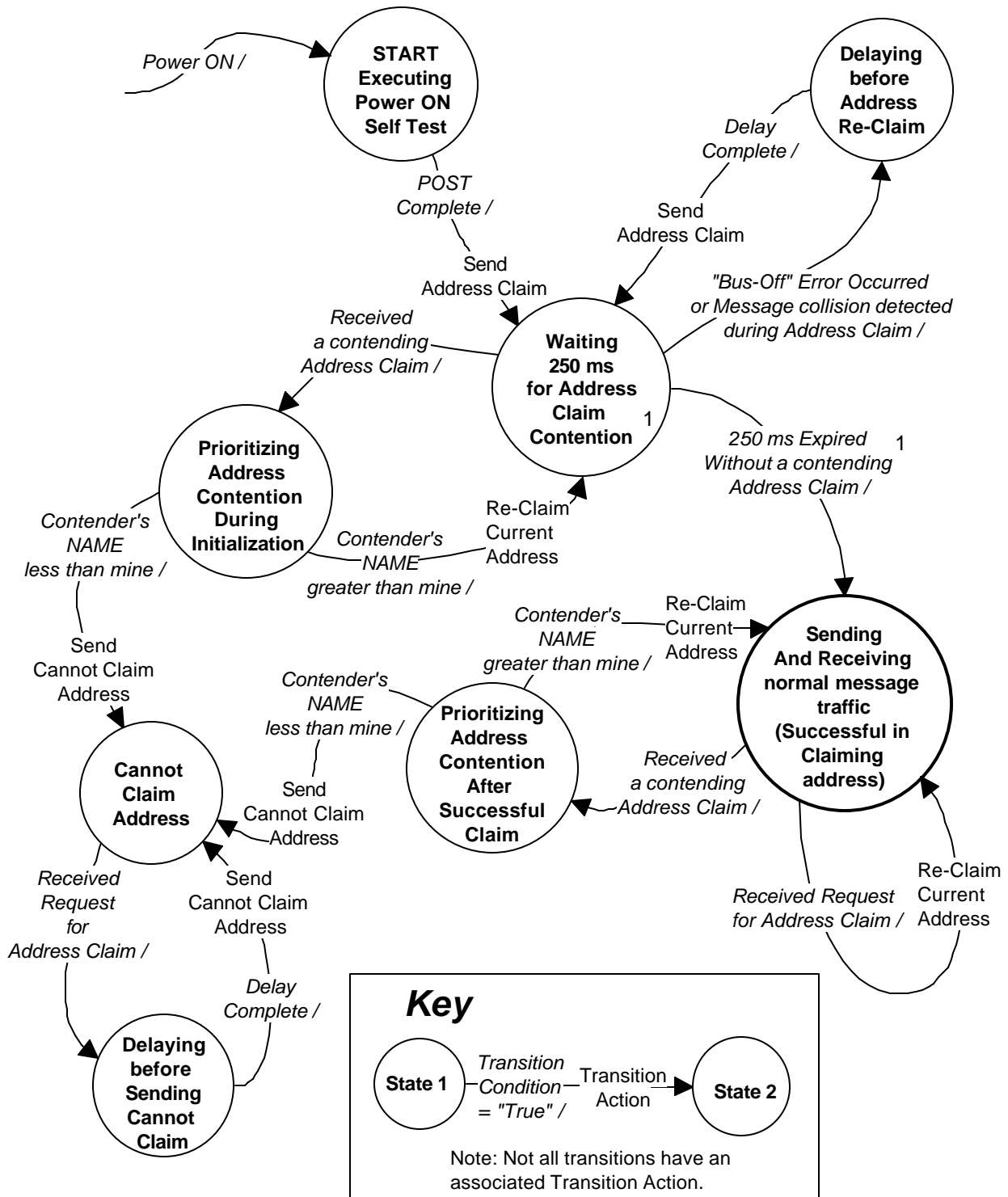

<sup>1</sup> CAs claiming addresses in the 0-127 and 248-253 ranges may omit the 250 ms delay.

FIGURE D2 - State Transition Diagram for Initialization of Single Address CAs

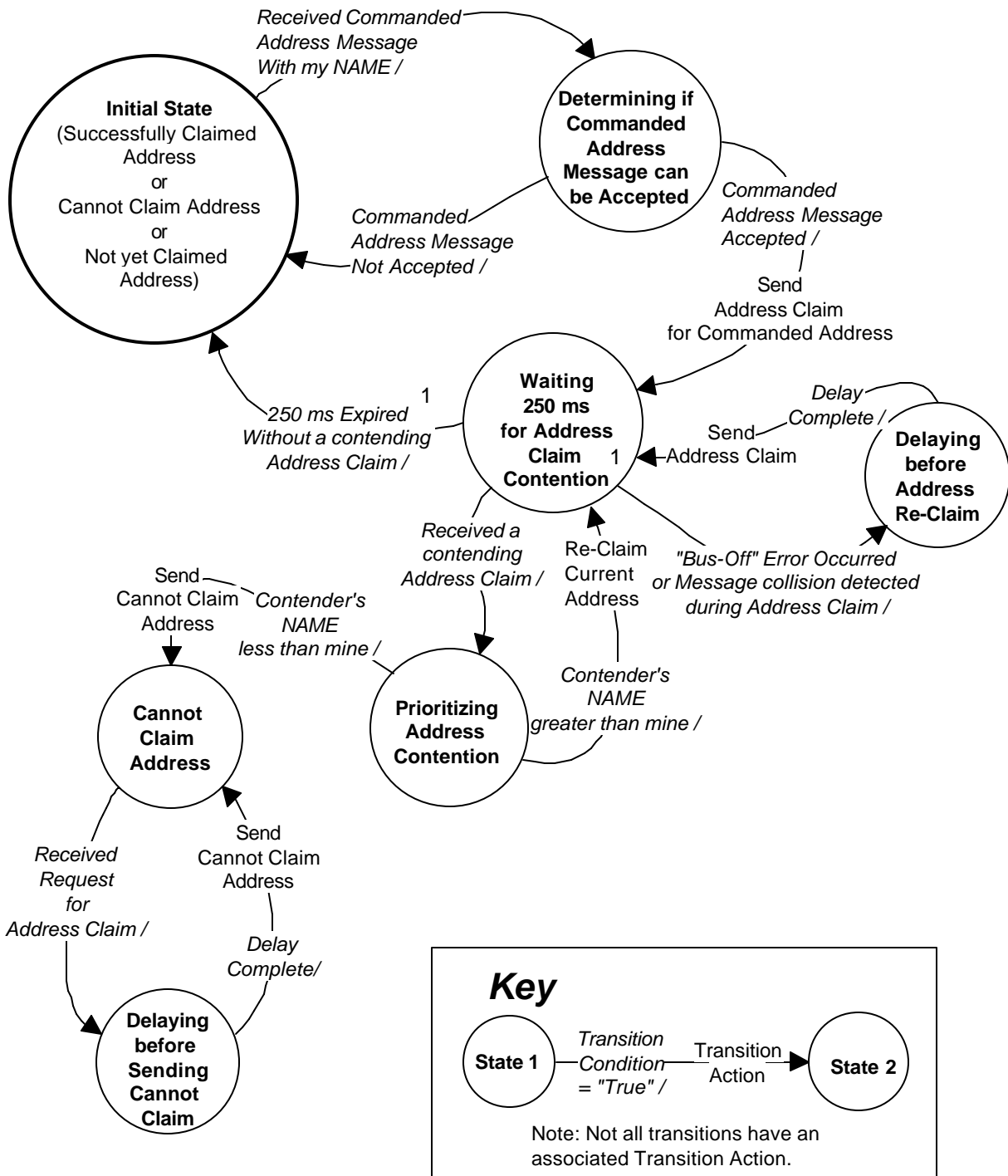

<sup>1</sup>CAs claiming addresses in the 0-127 and 248-253 ranges may omit the 250 ms delay.

FIGURE D3 - State Transition Diagram for Response of a CA to the Commanded Address Message

**Rationale** - Since the initial publication of SAE J1939-81 in 1997 the other layers of SAE J1939 have been further defined and the proposed uses of SAE J1939 have evolved beyond those foreseen at that time. Two major concepts have been added. Controller Applications introduces the idea of multiple applications running in one module. Working Sets addresses the use of multiple modules to perform a single coordinated function.

The definitions of all terms have been expanded and made consistent with other documents. Minimum requirements were updated. Examples have been improved and Appendices added.

**Relationship of SAE to ISO Standard** - Not Applicable.

**Application** - These Recommended Practices are intended for light and heavy-duty vehicles used on or off road as well as appropriate stationary applications which use vehicle derived components (e. g. generator sets). Vehicles of interest include, but are not limited to: on and off highway trucks and their trailers; construction equipment; and agricultural equipment and implements.

The purpose of these Recommended Practices is to provide an open interconnect system for electronic systems. It is the intention of these recommended practices to allow Electronic Control Units to communicate with each other by providing a standard architecture.

Network management in the SAE J1939 network is concerned with the management of source addresses and the association of those addresses with an actual functional and with the detection and reporting of network related errors. Due to the nature of management of source addresses, network management also specifies initialization processes, requirements for reaction to brief power outages, and minimum requirements for ECUs on the network.

### **Reference Section**

SAE J1587 - Joint SAE/TMC Electronic Data Interchange Between Microcomputer Systems in Heavy-Duty Vehicle Applications

SAE J1939 - Recommended Practice for Serial Control and Communications Vehicle Network

SAE J1939-21 - Data Link Layer

SAE J1939-31 - Recommended Practice for Serial Control and Communications Vehicle Network - Part 31- Network Layer

**Developed by the SAE Truck and Bus Control and Communications Subcommittee**

**Sponsored by the SAE Truck and Bus Electrical and Electronics Committee**